

# **GMAX-EOS2**

## **GPS Geotagger**

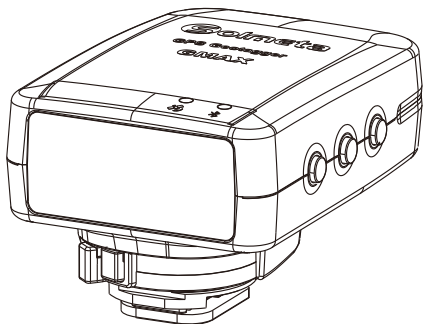

### **INSTRUCTION MANUAL** **Version 1.0**

**Camera Geotagger  
For Nikon or Canon  
GPS plus Beidou  
Barometric altimeter  
Position Tracing Logger  
Shutter Release Remoter  
LCD display  
Bluetooth technology  
GPS**



# Contents

Introduction.....	1
Main features .....	2
Highlights .....	3
Packing list.....	5
Part Names .....	6
Charging .....	7
Turning the Receiver On .....	8
Geotagging Image as you shoot .....	9
GPS/BDS logger.....	12
The main menu display.....	13
Custom setting.....	14
Access the custom setting .....	16
How to do the custom setting? .....	21
Other applications.....	34
Specifications .....	36
Warranty .....	37

# Introduction

Thank you for your purchase of a Solmeta GPS receiver GMAX-EOS2. The GMAX-EOS2 is a upgrade of the GMAX-EOS. The main improvement of the GMAX-EOS2 is the Bluetooth equipped. User can enable the Bluetooth to establish wireless connections to smart phone, which can then be used to control the camera and take pictures remotely.

## **Note**

To meet the requirement of some customers who prefer using a traditional remoter control instead of using smart phone, a real Wireless Remote Control (RC-1) is also sold separately.

### **Geotagging Images and Adding the Shooting Direction**

When the receiver connected to the camera, the location information (latitude, longitude, elevation) and shooting time (UTC, Coordinated Universal Time) can be added to the images as they are taken. Images can also be tagged with the shooting direction by using the receiver's digital compass.

### **GPS/BDS logger**

The receiver can be used as a tracking logger which keeps a record of location information along the route traveled.

Build in 4GB memory card and it supports more than 170 days continuous log record at the interval of 1 sec. User no longer worry about the size of the storage space.

### **Serving as a digital compass**

The direction, pitch and roll data can be clearly viewed. All the data are also recorded in log file.

### **Using as an accurate Clock**

The GMAX-EOS2 can be used as a very accurate independent clock. The accuracy is 0.1sec. The time can be adjusted by GPS/BDS intermittently.

### **Using as a wireless remoter**

While Solmeta "GMAX-Remoter" APP installed in smart phone, the GMAX-EOS2 and the smart phone can be used as a wireless remoter to control the camera and take pictures remotely.

**Note**, the real Wireless Remote Control (RC-1) is also sold separately.

# Highlights

## **LCD screen with size 38.5×16mm / 1.52 x0.63 in.**

- With the LCD, user can check the information below in real time
- GPS data
- Altitude (It is possible to detect altitude real time even indoor a room)
- Time and data (UTC and local time both are available)
- Speed
- Temperature
- Shooting direction (Digital compass)
- Heading (very useful for sail and flight)
- Pitch and Roll
- Signal strength

## **Dual positioning system, GPS plugs Beidou(BDS), user can choose preferred positioning system**

Fast signal acquisition and much more accurate positioning.

## **Build-in 3-axis digital compass can greatly improve the measurement precision of the heading angle, pitching angle and roll angel**

### **Build-in Barometric Altimeter**

The receiver provides two kinds of altitude data, one is from GPS, the other is from barometric altimeter. User can select the altitude according to the actual environment. The altitude from barometric altimeter can be adjusted and calibrated, which ensure the altitude more accurate.

## **Internal 1900mAh lithium rechargeable battery, no energy is drained from the camera's battery**

A full charge supports more than 18 hours of continuous work. User will no longer worry about the recharging in photographic day or on travel.

### **Indoor location**

Re-use the last received GPS information (Latitude, Longitude) when there is no GPS signal. The altitude, direction and UTC time are real time running by built-in sensors.

**Auto working mode**

The receiver is designed with Auto working mode. When choosing Auto working mode, the receiver is on / off following the connected camera's on / off. This is very convenient for photographer to use camera and GMAX-EOS2 together. In auto working mode, the receiver is always on standby and this ensures the receiver drains the power less and acquires the signal quickly.

# Packing list

Confirm that the package contains the following items

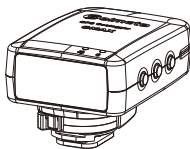

GMAX



Storage bag



Manual

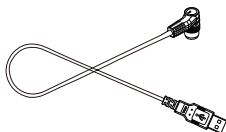

USB cable for charging  
downloading logging data

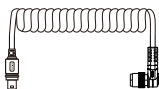

Connecting cable (Data cable)  
Cable-GEOS



Wireless Remote Control  
RC-1  
(Sold separately)



## Part Names

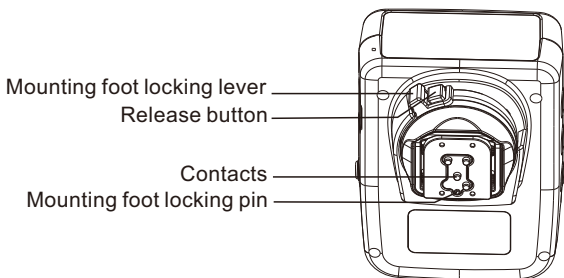
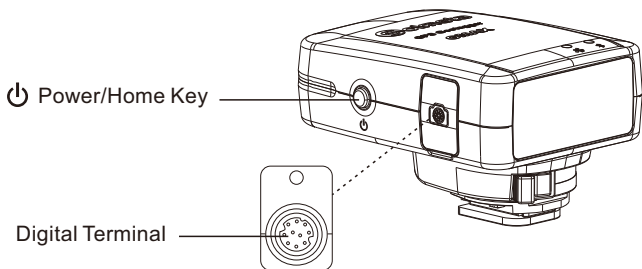
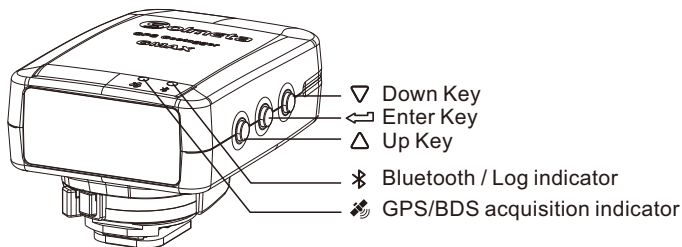

## Charging

The receiver is equipped a high-capacity lithium rechargeable battery, a full charge supports more than 18 hours of continuous work. The receiver can be charged by using any USB port that provides standard 5 volts.

### Note

- 3-4 hours for a full charge. The battery icon  in the LCD shows the battery level.
- The current voltage of battery can be checked anytime in custom setting.









## Turning the Receiver On

To turn on the receiver, press  for more than 3 seconds until the LCD shows



The firmware version will be displayed first, then the latitude and longitude will be displayed in the LCD.

## Turning the receiver off

1. Short press , the LCD shows a flashing 
2. Short press  or  until the LCD shows a flashing , and then short press  to turn off the receiver.
3. In some special situations, such as the receiver is software frozen and it cannot be turned off via upon operation. In this case, the receiver can be forced off by pressing  and  together.



## Acquiring GPS/BDS signals

To acquire GPS/BDS signals, bring the receiver outdoors where the sky is unobstructed and aim it up. Turn on the receiver to start automatic GPS/BDS signal acquisition. To check the acquisition status, watch the GPS/BDS indicator.

**Fast red blinking: Signal not acquired**

**Slow green blinking: Signal acquired, 2D positioning fixed**

**Stable green: Signal acquired, 3D positioning fixed**

When the receiver is searching the signal, a flashing  is displayed in the LCD. Once the signal acquired, the  will be stable and the latitude, longitude will be displayed in the LCD accordingly. The number in the top left indicates how many satellites are used.



## Geotagging Image as you shoot

Attach GMAX-EOS2 receiver to the camera's hot shoe, or connect the receiver to the camera via the data cable (connecting cable).

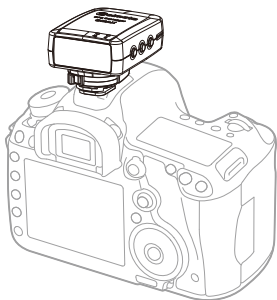

Hot shoe connection

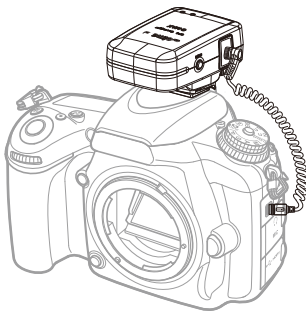

Digital terminal connection

### Note

Most of the EOS DSLR cameras support two connections. Some camera, such as EOS 7D, EOS1300D/Rebel T6, and EOS1200D/Rebel T5, they only support digital terminal connection.

Be sure to check the camera's manual to confirm which connection is applicable for yours.

## Checking camera < GPS > Icon

When the receiver is attached or connected to a camera, it can enable the menu item **[GPS device settings]**, GPS signal status is also shown on the camera's LCD panel or LCD monitor.

Blinking <GPS>: Signal not acquired yet

Constant <GPS>: Signal acquired

The <GPS> icon is only displayed when the receiver is communicating with the camera.

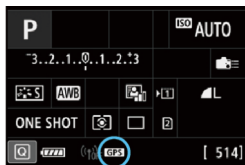

## Take picture and the images are geotagged

When the receiver attached or connected to a camera and the GPS icon is also constant, simply shoot and the images will be geotagged.

The image can also be tagged with the shooting direction using the receiver's digital compass. (Except with the EOS 7D, EOS 1300D/Rebel T6, and EOS 1200D/REBEL T5)

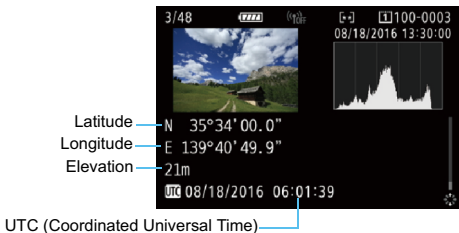







### Note

- Since each camera's GPS application is different, the user must refer to the camera's manual to know the detail of how to use the GPS receiver.
- If you wish to take geotagged photos in situations where the GPS signal is lost after it was acquired, such as when going indoors to continue shooting, the receiver's "indoor location" function, which is enabled by default, will reuse the last known position for subsequent image.
- Following with each shutter release, the image's GPS information also is recorded in the log file and the data is marked a "\*Flash\*" to indicate.

### Auto working mode

You can choose Auto working mode in your photography day. When choosing Auto working mode, the receiver is on or off following the connected camera's on or off. This ensures the receiver drains the power less and acquires the GPS signal quickly. The receiver is always on standby in Auto working mode. You can set the GPS working frequency and the working time of each time in Auto working mode. (See page 30)

### How to start the Auto working mode?

1. While the receiver is on, press  and the LCD shows a flashing 
2. Press  or  until a flashing  shown, and then press , a stable  will be displayed. The Auto working mode is activated.

## GPS/BDS logger

The GMAX-EOS2 can be used as a data logger. When the receiver is GPS/BDS signal fixed, location information can be automatically recorded on the receiver itself along the route traveled. (There is no need to connect the receiver to the camera.)

The recorded location information can be viewed on a virtual map. Logs can also be used to geotag images at a later time.

Location information is recorded at regular intervals with the receiver. You can specify the positioning interval via the custom setting. The default is every 10 seconds. For how to set the interval see page 32. The GMAX-EOS2 supports more than 170 days continuous log record at the interval of 1 sec.

To check the logging record status, watch the logging indicator and the **MEM** icon on the LCD.

**Red blinking: The logging indicator will blink once while the location information recorded.**

**MEM icon also will blink once while the location information recorded.**



The flash memory can be easily read by the computer via USB connection. Just like a “U flash driver”, no software needed. Log file can be saved or deleted on the computer.

The file system supports FAT32 format.

## The main menu display

When the receiver is GPS/BDS signal fixed, you can check the GPS/BDS information, compass data and other information in the LCD. Press  $\Delta$  or  $\nabla$ , the following 6 different displays will be shown in the LCD, one by one.

LCD	Description
	The char in the up indicate the latitude. The char on the bottom represent the longitude.
	The char in the up indicate the direction. The char on the bottom represent the pitch and roll.
	The char in the up indicate the current speed. The char on the bottom represent the altitude.
	The char in the up indicate the current speed. The char on the bottom represent the course over ground.
	The char in the up indicate the time (UTC or Local time). The char on the bottom represent the date. Note: Once the TIM displayed, it means the time is accurate as 1/10 seconds and the signal is 3D fixed.
	The char in the up indicate the internal temperature inside the receiver. The char on the bottom represent the air pressure.
	This is the custom setting.



**You can customize the following features to suit your preference.**

1. Which positioning system to be used, GPS, Beidou, or GPS+Beidou. The default is GPS+Beidou double positioning.
2. The display format of latitude and longitude  
     $.. .. ^\circ .. .. ' .. .. ''$  or  $.. .. ^\circ .. .. ' .. .. ''$
3. Enable the "Indoor fixing" or disable it. Indoor fixing means when you are into a place where is no a GPS signal, the receiver is able to provide the last GPS information.
4. The backlight of the LCD is on or off.
5. Signal acquisition indicator and Bluetooth/Log indicator are on or off.
6. The "beep" voice is on or off while pressing the button.
7. The Positioning Interval parameter synchronize with Camera
8. Enable the compass function or disable it.
9. Compass calibration.
10. Which direction data to be displayed, the data is based on true north or magnetic north.
11. Level calibration.
12. Select the speed unit, Mile, Kilometer or Knots.
13. Select the altitude unit, meter or feet.  
    Select which altitude data displayed, the data is from GPS or atmospheric pressure.
14. What kind of time to be shown on the LCD, UTC or Local time.  
    The local time can be set.
15. The date display format , DD.MM.YYYY, MM.DD.YYYY, or YYYY.MM.DD
16. The temperature unit, Fahrenheit or Centigrade. The temperature is the temperature inside of the receiver.
17. The air pressure unit, inHg, HPA, or bAR.
18. GPS/BDS working frequency and the working time of each time in Auto mode.
19. GPS/BDS working frequency and the working time of each time in Clock mode. (The time can be adjusted by GPS/BDS, which make the time accurate).

20. The available memory for logging. Set the logging interval, or turn off logging. The interval can be set as 1s, 5s, 10s, 15s, 30s, 1min., 2min., 5min., 10min., 20min., or 30min. 10 seconds is the default.
21. Enable the Bluetooth or disable it, also, choose the remote channel.
22. Restore the GMAX-EOS2 setting to factory.

**The following information can be checked in the custom setting**

1. The battery's current voltage.
2. The GPS/BDS chip's firmware version.

## Access the custom setting

1. When the receiver is on, press  $\Delta$  or  $\nabla$  until the LCD shows



2. To access the custom setting, press  $\leftarrow$  and the first setting of choosing the positioning system will be activated simultaneously



3. To access other setting, press  $\Delta$  or  $\nabla$ . To exit the custom setting and back to the main menu display, press  $\text{⏻}$

### Custom setting introduction

Menu Item	Option Item	Description
SAT	GPS bds GPS bds	Which positioning system to be used, GPS+Beidou, GPS or Beidou, GPS BDS: GPS plus Beidou, double position system GPS: Global Position System BDS: Beidou Position System
Geo DISP	..... .....	The display format of latitude and longitude.
INDOOR	LOCK UNLOCK	Enable the "Indoor fixing" or disable it. LOCK means Indoor fixing. When you are into a place where is no a GPS signal, the receiver is able to provide the last GPS information. UNLOCK means does not use the GPS information.

<p>BACK LED</p>	<p>ON → HIGH LIGHT  MID LIGHT  LOW LIGHT</p> <p>DELAY → 1 MIN  2 MIN  3 MIN  4 MIN  5 MIN</p> <p>OFF</p>	<p>The LCD backlight is on, off or delay off.  ON means the backlight is always on.  OFF means the backlight is always off.  Delay means the backlight will be automatically off a few minutes later.  When choosing on, 3 kind of different brightness can be selected, low light, middle light or high light.  When choosing delay off, the time can be set as 1min. 2min. 3min. 4min or 5min.</p>
<p>STATE LED</p>	<p>ON  OFF</p>	<p>The indicators of the GPS/BDS signal acquisition and the Blue tooth/Log are on or off.</p>
<p>BEEP</p>	<p>ON  OFF</p>	<p>The “beep” voice is on or off while pressing the button.</p>
<p>DATA INTVL</p>	<p>00:00:01</p>	<p>The time is the positioning interval of updating the geotag information.  The interval can also be set via camera setting.</p>
<p>DIR</p>	<p>ON  OFF</p>	<p>Enable the compass function or disable it.  This setting can also be set via camera setting.</p>

MAGNET CAL	[-----]	Compass calibration This setting can also be set via camera setting.
Direction data	MN TN	Direction is based on the data of true north or magnetic north. MN means the direction is based on magnetic north. TN means the direction is based on true north.
GPA CAL	--00' --00'	Level calibration
SPEED	MILE KNOT KM	The speed unit. Mile, Kilometer or Knots.
ALT	GPS-ALT AIR-ALT  FT m	The altitude unit, meter or feet. Which altitude data to be shown, the data from GPS/BDS or atmospheric pressure. The altitude data can be calibrated when choosing the atmospheric pressure data.
U or L	U  L	What kind of time to be shown in the LCD, UTC or Local time. L means Local time, U means UTC.
MM dd. " " "	MM dd. " " " dd MM. " " " " " " MM dd.	The date display format.

<p>F or C</p>	<p>F C</p>	<p>The temperature unit. F means Fahrenheit. C means Centigrade.</p>
<p>inHg bAP hPA</p>	<p>inHg bAP hPA → </p>	<p>The air pressure unit. inHg means Inch of Mercury 1bar=1000HPA The pressure value can be calibrated when choosing HPA.</p>
<p>AUTO SET</p>	<p>FRE CON</p>	<p>GPS/BDS working frequency and the working time of each time in Auto mode. FRE is the frequency. 10min, 15min, 30min, 60min, or 90min can be selected. CON is the working time. 1min, 3min, or 5min can be selected.</p>
<p>CLOCK SET</p>	<p>FRE CON</p>	<p>GPS/BDS working frequency and the working time of each time in Clock mode. FRE is the frequency. 1H, 2H, 4H, 8H, 24H, 48H, or 96H can be selected. CON is the working time. 1min, 3min, or 5min can be selected.</p>

<p>FAT 3773MB</p>	<p>00:00:01  00:00:05  00:00:10  00:00:15  00:30:00  d ISABLE</p>	<p>The number following the FAT is the available memory for logging.  Set the logging interval, or turn off logging. The interval can be set as 1sec, 5sec, 10sec, 15sec, 30sec, 1min., 2min, 5min, 10min, 20min and 30min. Disable means turn off the logging.  10 sec. is the default.</p>
<p>SET BLE</p>	<p>OFF  ON →  CH GMAX: 00</p>	<p>Turn on the Bluetooth connection or turn it off.  CH GMAX ** means the name of the device. The name can be set as 00, 01, 02, 03, 04, 05, 06, 07, 08, 09, 10, 11, 12, 13, 14, and 15.</p>
<p>bAT</p>	<p>bAT 4.15 V</p>	<p>The number following the bAT is the current voltage of the battery.</p>
<p>SAT  BLE</p>	<p>SAT 1.02  BLE V 1-2-7</p>	<p>The number following the SAT is the firmware version of the GPS/BDS chip.  The number following the BLE is the version of the Bluetooth.</p>
<p>SET  RESTORE ?</p>	<p>F IN ISH  SHUT DOWN</p>	<p>Restore the receiver to factory settings.</p>

## How to do the custom setting?

When the receiver is custom setting accessed, press  $\Delta$  or  $\nabla$  is to access next setting or change the option. Press  $\leftarrow$  is to activate current setting or complete the setting.

### Note

To exit the current setting and return to the main menu display, press  $\text{⏻}$ .

### Set the positioning system

1. While the LCD shows  press  $\leftarrow$  and the option menu will flash.

2. Press  $\Delta$  or  $\nabla$  to change the option

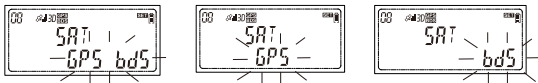

3. While your preferred positioning system appears, press  $\leftarrow$  to confirm your selection.

### Set the display format of latitude and longitude

1. While the LCD shows  press  $\leftarrow$  and the option menu will flash.

2. Press  $\Delta$  or  $\nabla$  to change the option



3. While your preferred display format appears, press  $\leftarrow$  to confirm your selection.



### Enable the “Indoor fixing” or disable it

1. While the LCD shows  press  $\leftarrow$  and the option menu will flash.

2. Press  $\Delta$  or  $\nabla$  to change the option

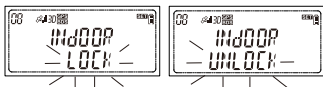

3. While your preferred option appears, press  $\leftarrow$  to confirm your selection.

### Set the LCD backlight on, off or delay off

1. While the LCD shows  press  $\leftarrow$  and the option menu will flash.

2. Press  $\Delta$  or  $\nabla$  to change the option



- 3.1 If you prefer ON, press  $\leftarrow$  while a flashing **ON** displayed, and the secondary option will flash.

Press  $\Delta$  or  $\nabla$  to change the option



While your preferred brightness appears, press  $\leftarrow$  to confirm your selection.

- 3.2 If you prefer Delay Off, press  $\leftarrow$  while a flashing **DELAY** displayed, and the secondary option will flash.

Press  $\Delta$  or  $\nabla$  to change the option, 1min, 2min, 3min, 4min or 5 min. While your preferred time appears, press  $\leftarrow$  to confirm your selection.

3.3 If you prefer OFF, press  $\leftarrow$  while a flashing OFF displayed and the backlight will be always off.

### Set the indicators of the GPS signal acquisition, logging and the Bluetooth are on or off

1. While the LCD shows  press  $\leftarrow$  and the option menu will flash.

2. Press  $\Delta$  or  $\nabla$  to change the option

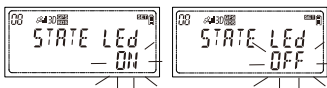

3. While your preferred option appears, press  $\leftarrow$  to confirm your selection.

### Set the “beep” voice on or off while pressing the button.

1. While the LCD shows  press  $\leftarrow$  and the option menu will flash.

2. Press  $\Delta$  or  $\nabla$  to change the option

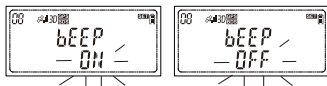

3. While your preferred option appears, press  $\leftarrow$  to confirm your selection.

### Setting the positioning interval of updating the geotag information. (The interval can also be set via camera setting)

1. While the LCD shows  press  $\leftarrow$  and the option menu will flash.



2. Press  $\Delta$  or  $\nabla$  to change the option, the option is the interval 1sec., 5sec., 10sec., 15sec., 30sec., 1min., 2min., 5min. can be selected.
3. While your preferred option appears, press  $\leftarrow$  to confirm your selection.

### Enable the compass function or disable it.

1. While the LCD shows  press  $\leftarrow$  and the option menu will flash.

2. Press  $\Delta$  or  $\nabla$  to change the option

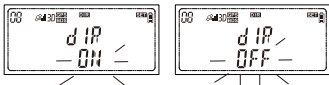

3. While your preferred option appears, press  $\leftarrow$  to confirm your selection.

### Doing the compass calibration

#### Why calibrate?

The compass in the receiver is sensitive to nearby magnetic objects that could cause measuring error. To compensate for this error, it is sometime necessary to perform a calibration. (If the compass is accurate, there is no need to perform the calibration)

#### How to calibrate?

1. While the LCD shows



Press  $\leftarrow$  and the LCD shows



2. Perform the follow operation

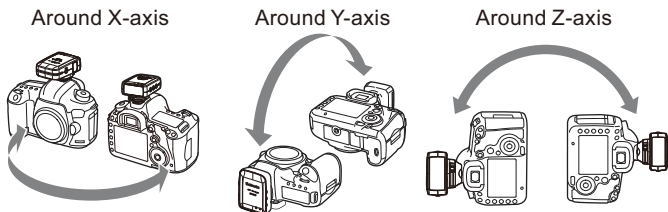

Hold the receiver, and rotate it slowly around the X-axis, Y-axis, and Z-axis, each axis done twice. Please do try to keep a constant speed of rotation, and each rotation takes almost 10 seconds.

3. After doing the rotation in each axis, press  $\leftarrow$  to complete the calibration.

**Select your preferred direction data, the data is based on true north or magnetic north.**

1. While the LCD shows  press  $\leftarrow$  and the option menu will flash.

2. Press  $\Delta$  or  $\nabla$  to change the option 

3.1 If you prefer  $||||$  press  $\leftarrow$  while the LCD shows a flashing 

and the LCD will show  It means the calibration mode is activated.

To do the calibration, press  $\leftarrow$  while pointing the receiver to the magnetic north. ( You should find the magnetic north in your location with help of other accurate compass. )

3.2 If you prefer **TN** press  $\leftarrow$  while the LCD shows a flashing



and the LCD will show  It means the calibration mode is activated.



To do the calibration, press  $\leftarrow$  while pointing the receiver to the true north. (You should find the true north in your location with help of map or others)

### Level calibration

1. While the LCD shows  press  $\leftarrow$  the pitch and the roll on the bottom will flash.



2. To do the level calibration, let the receiver in a horizontal position and then press  $\leftarrow$  the flashing pitch and roll will be stable. The calibration is completed.

### Set the speed unit

1. While the LCD shows  press  $\leftarrow$  and the option menu will flash.



2. Press  $\Delta$  or  $\nabla$  to change the option



3. While your preferred unit appears, press  $\leftarrow$  to confirm your selection.

**Select your preferred altitude unit, and select the altitude data is from GPS or atmospheric pressure**

1. While the LCD shows  press  $\leftarrow$  and the option menu will flash.

2. Press  $\Delta$  or  $\nabla$  to change the option

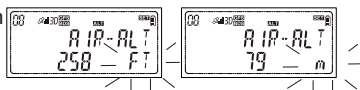

3. While your preferred unit appears, press  $\leftarrow$  to confirm your selection and the secondary option will flash. The secondary option is to select which altitude to be shown.

4. Press  $\Delta$  or  $\nabla$  to change the option *GPS-ALT* or *AIR-ALT*

- 4.1 If you prefer the altitude from GPS, press  $\leftarrow$  while a flashing

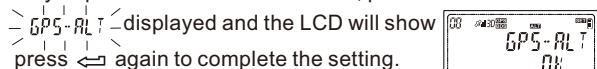

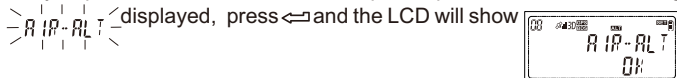

- 4.2 If you prefer the altitude from atmospheric pressure, while a flashing

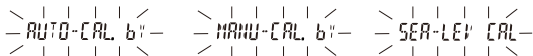

Press  $\leftarrow$  again and the third option will flash, the third option is to do the altitude calibration in different way.

Press  $\Delta$  or  $\nabla$  to change the option



- 4.2.1 If you prefer using the GPS data as the reference to do the calibration, while the LCD shows  press  $\leftarrow$  and the

LCD will show  press  $\leftarrow$  again to complete the calibration.

- 4.2.2 If you prefer using the sea level pressure as the reference to do the calibration, while the LCD shows



press  $\leftarrow$  and the value on the bottom will flash. Press  $\Delta$  or  $\nabla$  and  $\leftarrow$  to adjust the value. While the value is adjusted to the sea-level pressure issued by the local observatory, press  $\leftarrow$  and the LCD will show



press  $\leftarrow$  again to complete the calibration.

- 4.2.3 If you prefer using the altitude as the reference to do the calibration, while the LCD shows



press  $\leftarrow$  and the value on the bottom will flash. Press  $\Delta$  or  $\nabla$  and  $\leftarrow$  to adjust the value. While the value adjusted to the altitude of your location which is known in advance, press  $\leftarrow$  to complete the calibration.

### Set what kind of time to be shown on the LCD, UTC or Local time

1. While the LCD shows

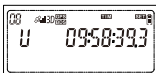

press  $\leftarrow$  and the option menu will flash.

2. Press  $\Delta$  or  $\nabla$  to change the option

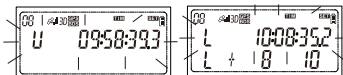

- 3.1 If you prefer the UTC, while a flashing



displayed, press  $\leftarrow$  to confirm your selection.

- 3.2 If you prefer the local time, press  $\leftarrow$  while a flashing



displayed, and the secondary setting option on the bottom will flash



The secondary setting is to set the local time.

Press  $\Delta$  or  $\nabla$  to add or reduce the time zone and the time will be changed accordingly. While the local time is adjusted to the current local time, press  $\leftarrow$  again to complete the setting and the LCD will show the local time.

### Set the date display format

1. While the LCD shows  press  $\leftarrow$  and the option menu will flash.



2. Press  $\Delta$  or  $\nabla$  to change the option



3. While your preferred display format appears, press  $\leftarrow$  to confirm your selection.

### Set the temperature unit

1. While the LCD shows  press  $\leftarrow$  and the option menu will flash.



2. Press  $\Delta$  or  $\nabla$  to change the option



3. While your preferred unit appears, press  $\leftarrow$  to confirm your selection.







## Set the air pressure unit

1. While the LCD shows  press  $\leftarrow$  and the option menu will flash.

2. Press  $\Delta$  or  $\nabla$  to change the option



- 3.1 If you prefer the unit as inHg, press  $\leftarrow$  while a blinking  displayed and the flashing char will be stable.
- 3.2 If you prefer the unit as bar, press  $\leftarrow$  while a flashing  displayed and the flashing char will be stable.
- 3.3 If you prefer the unit as HPA, press  $\leftarrow$  while a flashing  displayed and the LCD will show  it means the calibration mode is activated.

To do the calibration, press  $\Delta$  or  $\nabla$  to adjust the value. While the value is adjusted to the reference value of your location, press  $\leftarrow$  to complete the calibration.

### Note

**The calibration value is default by factory. You can only do the calibration when the reference value of your local observatory issued is available. The factory default cannot be changed even perform the restore setting.**

## Set GPS/BDS working frequency and the working time of each time in Auto mode

1. While the LCD shows  press  $\leftarrow$  and the LCD

will show



## How to do the custom setting?

Press  $\leftarrow$  again and the option will flash



2. Press  $\Delta$  or  $\nabla$  to change the option, the option is the GPS working frequency. 10min, 15min, 30min, 60min, or 90min can be selected.

3. While your preferred frequency appears, press  $\leftarrow$  and the LCD will show as



4. Press  $\leftarrow$  again and the option will flash



5. Press  $\Delta$  or  $\nabla$  to change the option, the option is the GPS working time of each time. 1min, 3min, or 5min can be selected.

6. While your preferred working time appears, press  $\leftarrow$  to confirm your selection.

## Set GPS/BDS working frequency and the working time of each time in Clock mode

1. While the LCD shows



press  $\leftarrow$  and the LCD

will show as



2. Press  $\leftarrow$  again and the option will flash



3. Press  $\Delta$  or  $\nabla$  to change the option, the option is the GPS working frequency. 1hr, 2hr, 4hr, 8hr, 24hr, 48hr, or 96hr can be selected.

4. Press  $\leftarrow$  while your preferred frequency, and the LCD will show



5. Press  $\leftarrow$  again and the option will flash



6. Press  $\Delta$  or  $\nabla$  to change the option, the option is the GPS working time of each time. 1min, 3min, or 5min can be selected.

7. While your preferred working time appears, press  $\leftarrow$  to confirm vselection.

### Set the regular interval of logging the travel routes

1. While the LCD shows



press  $\leftarrow$  and the LCD will

show



2. Press  $\leftarrow$  again and the option menu will flash



3. Press  $\Delta$  or  $\nabla$  to change the option, the option is the interval.

1sec, 5sec, 10sec, 15sec, 30sec, 1min, 2min, 5min, 10min, 20min.

30min or disable can be selected. Disable means turn off the logging.

4. While your preferred interval appears, press  $\leftarrow$  to confirm your selection.

### Turn on the Bluetooth or turn it off

1. While the LCD shows



press  $\leftarrow$  and the option menu

will flash.

2. Press  $\Delta$  or  $\nabla$  to change the option

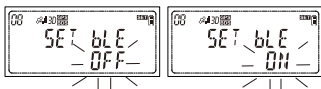

3.1 To turn on the Bluetooth, press  $\leftarrow$  while the LCD shows



and the LCD will show



it is to set the device name.

Press  $\Delta$  or  $\nabla$  to choose your wanted name, the name can be set as 00, 01, 02, 03, 04, 05, 06, 07, 08, 09, 10, 11, 12, 13, 14, and 15.

While your preferred name appears, press  $\leftarrow$  to confirm your selection.

3.2 To turn off the bluetooth, press  $\leftarrow$  while the LCD shows



The default is turn off.

### Restore the receiver

1. While the LCD shows



press  $\leftarrow$  and the LCD

will show









2. Press  $\leftarrow$  again and the receiver will automatically turn off. The receiver is restored.

### An accuracy clock

The receiver can be used as an accuracy clock. The time can be adjusted by GPS/BDS. You can set the GPS working frequency in custom setting. See page 31

### How to run the clock mode?

1. While the receiver is on, press  and the LCD shows a flashing 
2. Press  or  until a flashing  is shown, and then press 

The clock mode is activated and the LCD only shows the time information.

3. To exit the clock mode, press 

### Note

- The last char in the LCD is fast running

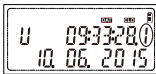

press  can get the char stable.

- If you prefer the local time shown in the clock, you can do the setting in custom setting. See page 28

## Wireless remoter

While the GMAX-EOS2 connected to the camera, get the GMAX-EOS2 wireless connected to a smart phone via the Bluetooth, which can then be used to control the camera and take pictures remotely.

1. To use the GMAX-EOS2 and the smart phone as a camera wireless remoter, a “GMAX-Remoter” APP should be installed in the smartphone in advance.

For iPhone iOS user, the APP can be searched in the “App Store” by inputting the key words of “GMAX-Remoter”.

For Android user, please go to [www.solmeta.com](http://www.solmeta.com) to download the GMAX-Remoter APP.

2. Ensure that the Bluetooth of your GMAX-EOS2 and your smartphone are on and the GMAX-EOS2 has been connected to the camera properly.

**Note. The Bluetooth is off and the channel (device name) is GMAX00 by default.**

3. Running the “GMAX-Remoter” APP in your smartphone. The APP will get the GMAX-EOS2 and the smartphone communicated. If the communication is successful, the Bluetooth indicator on the receiver will green light up.

4. Use the APP to control the camera and take pictures remotely.  
For how to use the APP please refer to the “About” in the APP.



## Specifications

Compatible cameras	EOS DIGITAL cameras Cameras with <b>[GPS device settings]</b> menu item: All features available Cameras without <b>[GPS device settings]</b> menu item: LOG mode available
Geotagging Images	Latitude, longitude, elevation, direction, time (UTC) and signal acquisition GPS-compatible camera: can be tagged during shooting ( EOS 7D and EOS REBEL T5 / EOS1200D / EOS1300D do not support tagging the shooting direction)
Internal memory	4 GB
Reception frequency	L1, 1575.42 MHz B1, 1561.098MHz
Data format	NMEA-0813
Data update rate	One time per second
Time adjustment	Camera time can be set from GPS time date
Digital compass	Tri-axial geomagnetic sensor and tri-axial acceleration sensor used to calculate direction
Power supply	1900 mAh Li-ion
Dimensions	55 x 75 x 45 mm /2.2 x 3. 0 x1. 8 in. (W x H x D)
Weight	Approx. 110 g / 3. 8 oz.
Operating temperature	-40°C to +80°C /*-40° F to 176° F
Operating humidity	5% to 95%, Non condensing

- Receiver specifications and appearance are subject to change without notice.

# Warranty

- Solmeta Technology Co., Limited guarantees its product from manufacturing defects and workmanship for a period of **two-year** from the date of original purchase. During the two-year warranty, Solmeta Technology will repair or replace the product free of charge. Please keep your original invoice as proof of purchase.
- Customers who have products covered under the warranty are required to contact Solmeta Technology by e-mail (service@solmeta.com) for troubleshooting issues before returning the product.
- Customers are responsible for shipping and insurance charges for returning the product to Solmeta Technology.
- Charges will be imposed for repairing product, which is out of warranty coverage or invalid warranty.
- The guarantee is not valid if defect is due to damage caused by incorrect use, poor maintenance or if persons not authorized by Solmeta Technology have carried out alterations or repairs.
- For the device to be used correctly, the user should strictly adhere to all instructions included in the user guide and should abstain from any actions or uses that are described as undesired or which are warned against in the user guide.

## Precautions for use

**Do not drop:** The product may malfunction if subjected to strong shocks or vibration.

**Keep dry:** This product is not waterproof, and may malfunction if immersed in or exposed to water.

**Avoid sudden changes in temperature:** Sudden changes in temperature, such as occur when entering or leaving a heated building on a cold day, can cause condensation inside the device. To prevent condensation, place the device in a carrying case or plastic bag before exposing it to sudden changes in temperature.



**Keep away from strong magnetic fields:** Do not use or store this device in the vicinity of equipment that generates strong electromagnetic radiation or magnetic fields. Strong static charges or the magnetic fields produced by equipment such as radio transmitters could affect the product's internal circuitry.

**A note on electronic devices:** In extremely rare instances, a strong external static charge may cause the device to stop functioning. Turn the camera off and disconnect and reconnect the GMAX-EOS2. In the event of continued malfunction, contact your retailer or Solmeta-authorized service representative.

**Information in this document is subject to change without notice. Solmeta Technology reserves the right to change or improve their products and to make changes in the content without obligation to notify any person or organization of such changes or improvements.**







**Shenzhen Solmeta Technology Company**

Add: Room 327, Building 5, Zhong Xing Industrial Town,  
Chuang Ye Road, Nan Shan district, Shenzhen, 518054, China  
Tel: +86-755-26969187  
E-Mail: [service@solmeta.com](mailto:service@solmeta.com)  
Web: [www.solmeta.com](http://www.solmeta.com)

**PRINTED IN CHINA**